

Trittico Business 305

A whole gelato workshop in a single machine
water cooled

Model:
Quantity:
Project:
Company:
Contact:
Dealer ID:

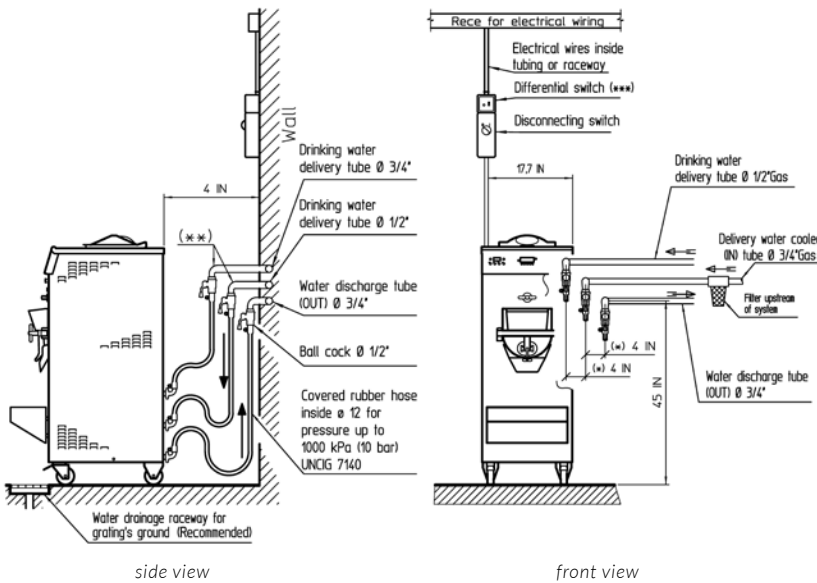
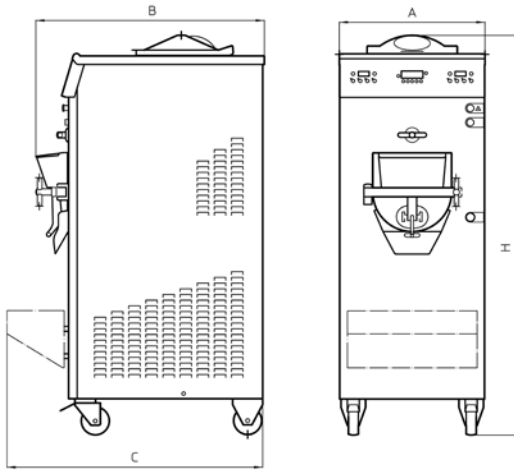

(*) Even if the machine models vary, the water and electricity connection positions are always the same, i.e. on the LEFT side of the machine.
(**) Cocks are in vertical only for illustration purposes.
(***) 30 mA (ABB serie C).

Height (H)	cm	140	inches	55,1
Depth (B)	cm	80	inches	31,5
Depth with shelf (C)	cm	87,5	inches	34,5
Width (A)	cm	51	inches	20
Weight	kg	252	lbs	555
Frame type	countertop			
Outer panels	stainless steel			
Prod. for cycle	Liters	5	Gal	1,32
Min. continuous hourly production	Liters	20	Gal	5,3
Max production rate	Liters	30	Gal	7,9
Min. mix for cycle	kg	2	lbs	4,4
Max. mix per cycle	kg	4	lbs	8,8
Volume cylinder with mixer	Liters	8,94	Quarts	7,86
Volume cylinder without mixer	Liters	9,46	Quarts	8,32
Stirrer speed	122 RPM			
Mixer speed	250 RPM			
Max Power	kW	6,2	Hp	8,3
Voltage	230 Volt/60 Hz/3 phase			
Running Amps	Amp 18,4			
Breaker size	Amp 40			
Stirrer motor	kW	0,21	Hp	0,28
Drive motor	kW	2,2 - 1,35	Hp	3 - 1,8
Compressor power	kW	1,5	Hp	2
Compressor Capacity (EV: 23°F)	BTU/h 19000			
Freon R404A	g	1150	Oz	40,6
Refrigeration condensation	Water			
Water connection	cm	1,27	inches	1/2
Min. water pressure	bar	2	Psi	29
Max. water pressure	bar	3	Psi	43,5
Crate dimensions	cm	95 x 62 x 157	inches	37,4 x 24,5 x 61,8
Crate weight	kg	278	lbs	613



Warranty: valid for the North American Continent (Canada, USA)
Extension: 12 months parts (with check list and warranty signed and mailed)
5 years compressor with registration on warranty.bravonorthamerica.com



Bravo North America Inc. Office & Showroom, 810 Tyvola Road, Suite 130, Charlotte, NC 28217
tel. +1 980 237 2474 bravonorthamerica.com info@bravonorthamerica.com

Trittico Business 305

A whole gelato workshop in a single machine
air + water cooled

Model:
Quantity:
Project:
Company:
Contact:
Dealer ID:

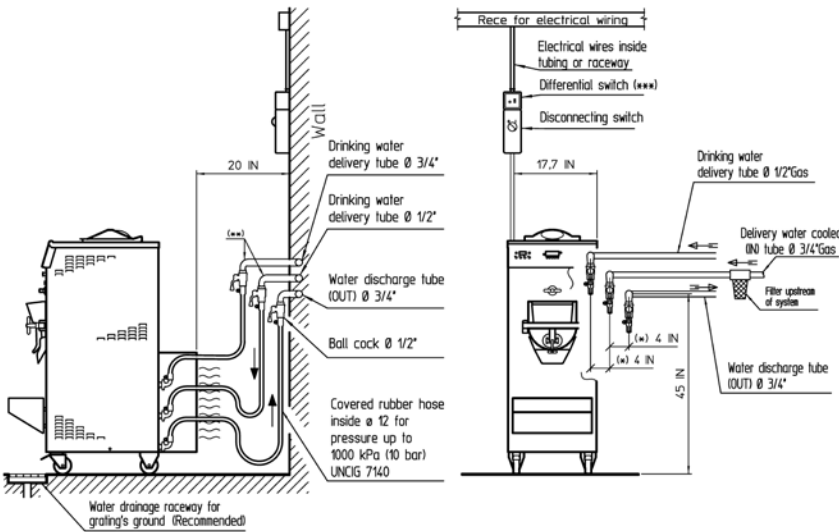
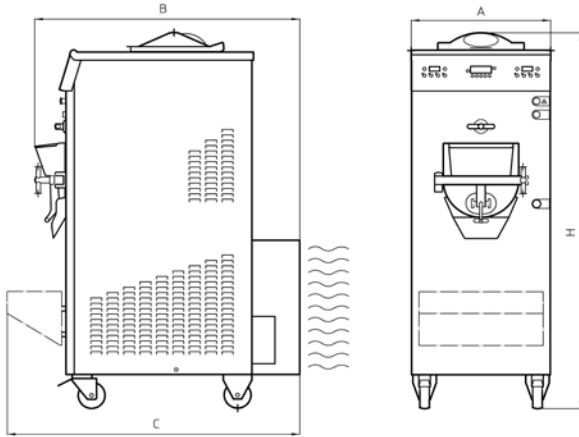

side view

front view

(*) Even if the machine models vary, the water and electricity connection positions are always the same, i.e. on the LEFT side of the machine.
(**) Cocks are in vertical only for illustration purposes.
(***) 30 mA (ABB serie C).

Height (H)	cm	140	inches	55,1
Depth (B)	cm	97	inches	38
Depth with shelf (C)	cm	103,5	inches	40,8
Width (A)	cm	51	inches	20
Weight	kg	252	lbs	555
Frame type	countertop			
Outer panels	stainless steel			
Prod. for cycle	Liters	5	Gal	1,32
Min. continuous hourly production	Liters	20	Gal	5,3
Max production rate	Liters	30	Gal	7,9
Min. mix for cycle	kg	2	lbs	4,4
Max. mix per cycle	kg	4	lbs	8,8
Volume cylinder with mixer	Liters	8,94	Quarts	7,86
Volume cylinder without mixer	Liters	9,46	Quarts	8,32
Stirrer speed	122 RPM			
Mixer speed	250 RPM			
Max Power	kW	6,6	Hp	8,85
Voltage	230 Volt/60 Hz/3 phase			
Running Amps	Amp 17,5			
Breaker size	Amp 40			
Stirrer motor	kW	0,21	Hp	0,28
Drive motor	kW	2,2 - 1,35	Hp	3 - 1,8
Compressor power	kW	1,5	Hp	2
Compressor Capacity (EV: 23°F)	BTU/h 19000			
Freon R404A	g	2300	Oz	81,1
Refrigeration condensation	Air + Water			
Water connection	cm	1,27	inches	1/2
Min. water pressure	bar	2	Psi	29
Max. water pressure	bar	3	Psi	43,5
Crate dimensions	cm	95 x 62 x 157	inches	37,4 x 24,5 x 61,8
Crate weight	kg	278	lbs	613



Warranty: valid for the North American Continent (Canada, USA)
Extension: 12 months parts (with check list and warranty signed and mailed)
5 years compressor with registration on warranty.bravonorthamerica.com



Bravo North America Inc. Office & Showroom, 810 Tyvola Road, Suite 130, Charlotte, NC 28217
tel. +1 980 237 2474 bravonorthamerica.com info@bravonorthamerica.com

Trittico Business 610

A whole gelato workshop in a single machine
water cooled

Model:
Quantity:
Project:
Company:
Contact:
Dealer ID:

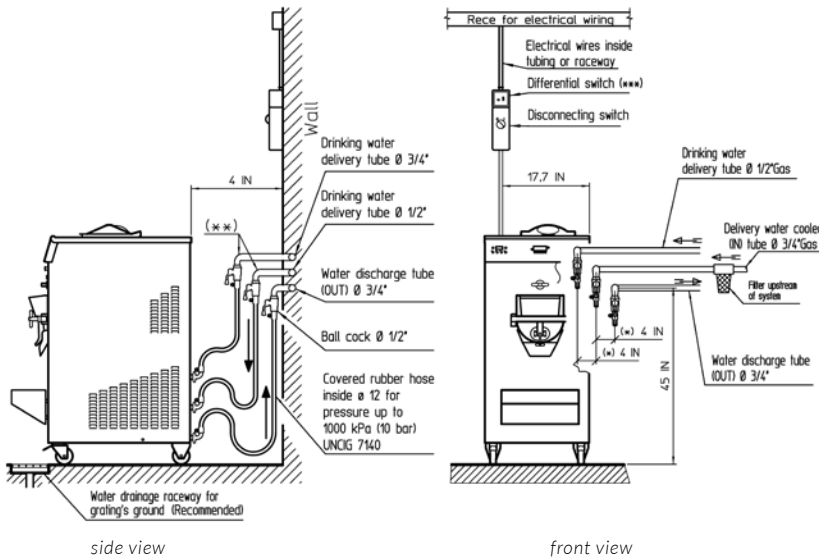
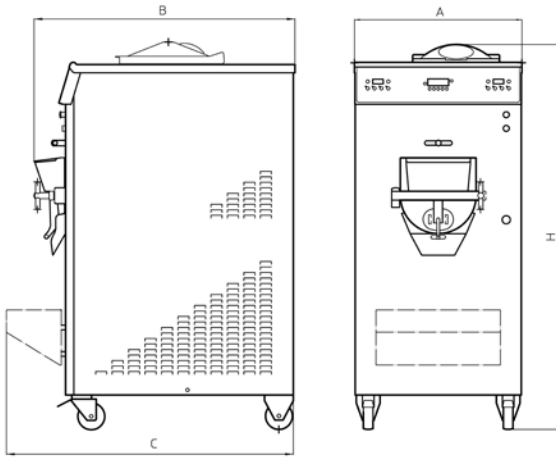

(*) Even if the machine models vary, the water and electricity connection positions are always the same, i.e. on the LEFT side of the machine.
(**) Cocks are in vertical only for illustration purposes.
(***) 30 mA (ABB serie C).

Height (H)	cm	141	inches	55,5
Depth (B)	cm	95	inches	37,5
Depth with shelf (C)	cm	102,5	inches	40,4
Width (A)	cm	61	inches	24
Weight	kg	341	lbs	752
Frame type	countertop			
Outer panels	stainless steel			
Prod. for cycle	Liters	10	Gal	2,64
Min. continuous hourly production	Liters	40	Gal	10,6
Max production rate	Liters	60	Gal	15,8
Min. mix for cycle	kg	4	lbs	8,8
Max. mix per cycle	kg	8	lbs	17,6
Volume cylinder with mixer	Liters	15,83	Quarts	13,93
Volume cylinder without mixer	Liters	16,64	Quarts	14,64
Stirrer speed	122 RPM			
Mixer speed	250 RPM			
Max Power	kW	10,8	Hp	14,4
Voltage	230 Volt/60 Hz/3 phase			
Running Amps	Amp 29,8			
Breaker size	Amp 63			
Stirrer motor	kW	0,21	Hp	0,28
Drive motor	kW	4,8 - 2,6	Hp	6,4 - 3,5
Compressor power	kW	2,9	Hp	3,9
Compressor Capacity (EV: 23°F)	BTU/h 39000			
Freon R404A	g	2000	Oz	70,5
Refrigeration condensation	Water			
Water connection	cm	1,27	inches	1/2
Min. water pressure	bar	2	Psi	29
Max. water pressure	bar	3	Psi	43,5
Crate dimensions	cm	109 x 72 x 157	inches	42,9 x 28,3 x 61,8
Crate weight	kg	380	lbs	838



Warranty: valid for the North American Continent (Canada, USA)
Extension: 12 months parts (with check list and warranty signed and mailed)
5 years compressor with registration on warranty.bravonorthamerica.com



Bravo North America Inc. Office & Showroom, 810 Tyvola Road, Suite 130, Charlotte, NC 28217
tel. +1 980 237 2474 bravonorthamerica.com info@bravonorthamerica.com

Trittico Business 1020

A whole gelato workshop in a single machine
water cooled

Model:
Quantity:
Project:
Company:
Contact:
Dealer ID:

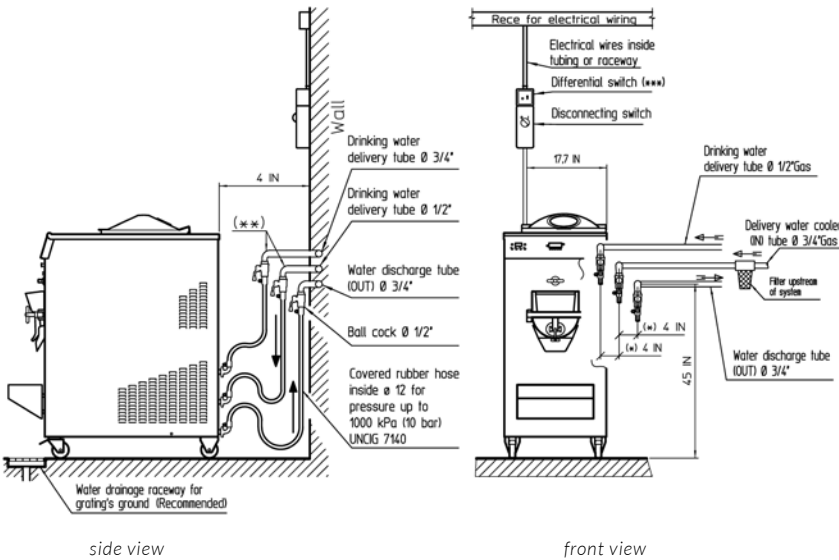
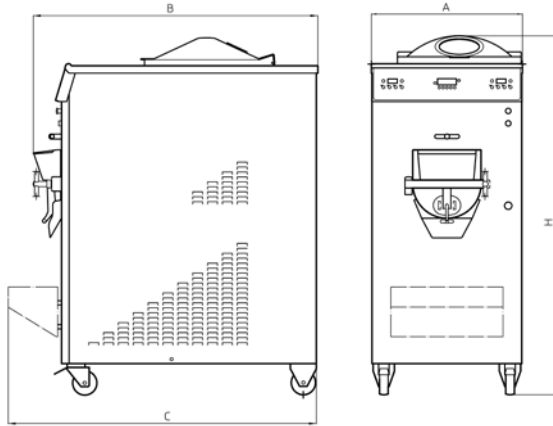

Height (H)	cm	144	inches	56,7
Depth (B)	cm	115	inches	45,3
Depth with shelf (C)	cm	122,5	inches	48,2
Width (A)	cm	61	inches	24
Weight	kg	515	lbs	1135
Frame type	countertop			
Outer panels	stainless steel			
Prod. for cycle	Liters	20	Gal	5,28
Min. continuous hourly production	Liters	80	Gal	21,1
Max production rate	Liters	120	Gal	31,7
Min. mix for cycle	kg	8	lbs	17,6
Max. mix per cycle	kg	16	lbs	35,3
Volume cylinder with mixer	Liters	26,05	Quarts	22,92
Volume cylinder without mixer	Liters	27,63	Quarts	24,31
Stirrer speed	122 RPM			
Mixer speed	250 RPM			
Max Power	kW	18,6	Hp	25
Voltage	230 Volt/60 Hz/3 phase			
Running Amps	Amp 61,2			
Breaker size	Amp 100			
Stirrer motor	kW	0,45	Hp	0,6
Drive motor	kW	7,5 - 4,8	Hp	10 - 6,4
Compressor power	kW	3,75	Hp	5
Compressor Capacity (EV: 23°F)	BTU/h 55000			
Freon R404A	g	2999	Oz	105,8
Refrigeration condensation	Water			
Water connection	cm	1,27	inches	1/2
Min. water pressure	bar	2	Psi	29
Max. water pressure	bar	3	Psi	43,5
Crate dimensions	cm	123 x 72 x 157	inches	48,4 x 28,3 x 61,8
Crate weight	kg	560	lbs	1234

(*) Even if the machine models vary, the water and electricity connection positions are always the same, i.e. on the LEFT side of the machine.

(**) Cocks are in vertical only for illustration purposes.

(***) 30 mA (ABB serie C).



Warranty: valid for the North American Continent (Canada, USA)
Extension: 12 months parts (with check list and warranty signed and mailed)
5 years compressor with registration on warranty.bravonorthamerica.com



Bravo North America Inc. Office & Showroom, 810 Tyvola Road, Suite 130, Charlotte, NC 28217
tel. +1 980 237 2474 bravonorthamerica.com info@bravonorthamerica.com