



KIOSKO Z11



ES EL PUNTO DE VENTA IDEAL. LA MANERA MÁS ORIGINAL Y ATRACTIVA DE OFRECER ZUMO RECIÉN EXPRIMIDO, ALIMENTOS Y OTROS PRODUCTOS



- Estructura de fibra de vidrio, color naranja.
- 4 ruedas (2 con freno).
- Mecanismo de apertura sube-baja manual, con bloqueo de seguridad.
- Puerta de acceso lateral con cerradura.
- Instalación eléctrica con tomas de luz.
- 4 luces que añaden atractivo visual.
- Instalación de agua con bomba de pie.
- Fregadero y banco de acero inoxidable.
- Estantería interior para productos ligeros.
- Todo el diámetro de la esfera sirve de mostrador, dotándole de mayor superficie útil de venta y atención al público.
- Espacio para instalar otro equipamiento: refrigerador, cafetera, etc.
- Exprimidores adaptables: Z14, Z05, Z08, así como sus conjuntos.

THE IDEAL MOBILE JUICE BAR. THE MOST ORIGINAL AND ATTRACTIVE WAY OF OFFERING FRESHLY-SQUEEZED ORANGE JUICE, DRINKS & SNACKS

- Fibreglass structure.
- 4 wheels (2 with brakes).
- Manual raise-and-lower opening mechanism with safety bolt.
- Lockable side door for access.
- Electrical installation with sockets.
- Four lights enhance its visual appeal.
- Water installation with foot pump.
- Stainless steel sink and worktop.
- Interior shelf for lightweight products.
- The whole diameter of the sphere can be used as a counter, providing a spacious sales area for dealing with customers.
- Space for installing other equipment, e.g. fridge, coffee machine, etc.
- Adaptable to various squeezer models: Z14, Z05, Z08 and their different sets.

CARACTERÍSTICAS TÉCNICAS

PESO: 300 Kg

TECHNICAL CHARACTERISTICS

WEIGHT: 300 Kg

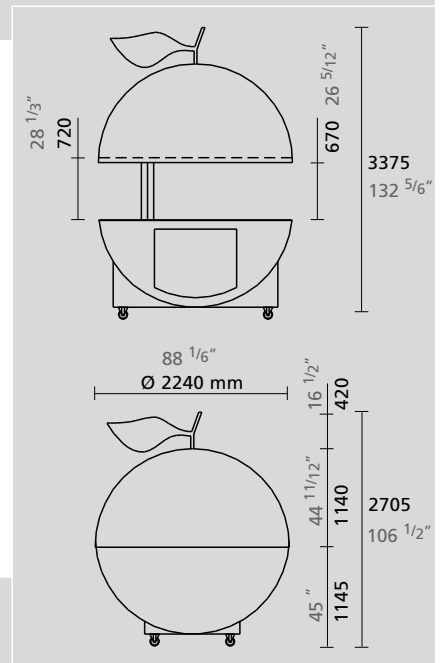

MEDIDAS
SIZES