

# 430

## Frozen Beverage Freezer

Single Flavor

### Features

Vary your menu by offering shakes & smoothies or frozen cocktails, fruit juices, coffees, cappuccino and tea slush beverages, all served at the desired thickness.

### Freezing Cylinder

One, 4 quart (3.8 liter).

### Mix Hopper

One, 14 quart (13.2 liter). Refrigerated to maintain mix below 41°F (5°C). Approved for dairy and non-dairy products.

### Indicator Lights

Add Mix light alerts the operator to add mix. When the Mix Out light flashes, the unit automatically shuts down to prevent damage.

### Automatic Consistency Control

A specially designed viscosity control automatically maintains superior product quality. An adjustable control allows the operator to serve a wide variety of frozen beverages at the desired thickness.



Shown with optional panel decals



Standard 6 & 18



SA2650



Selected 50 Hz. Models

# 430 Frozen Beverage Freezer

430

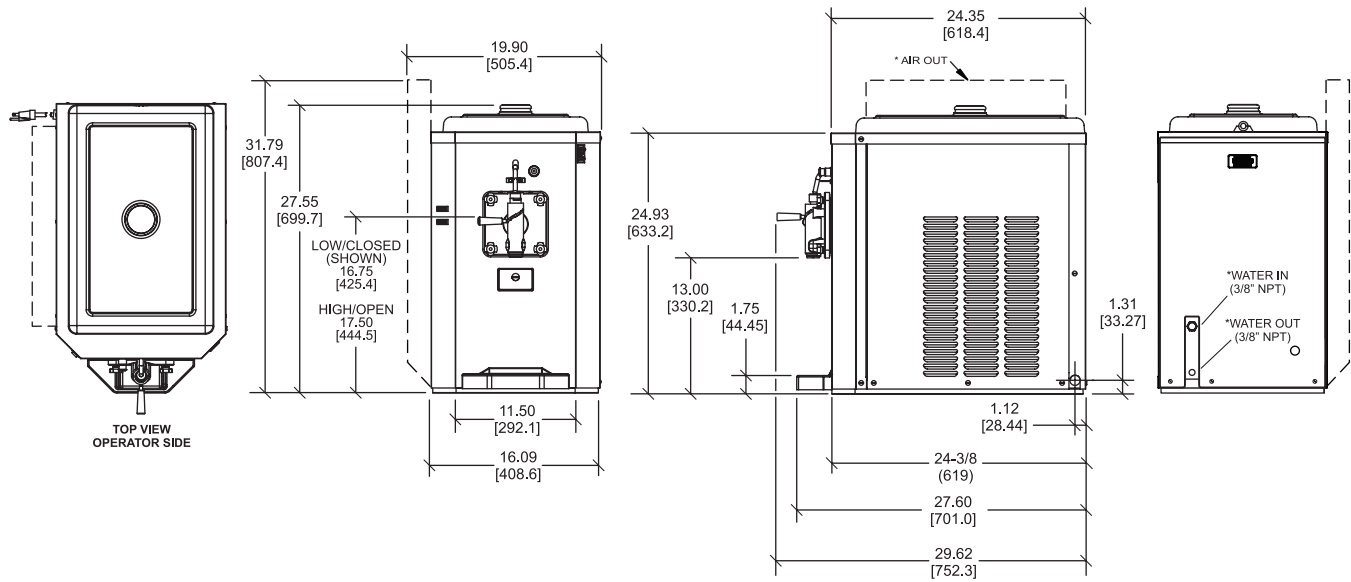

FIGURES IN BRACKETS INDICATE MILLIMETERS / DECIMAL DIMENSIONS EQUAL TO ( PLUS OR MINUS 1/16 INCH [1.5mm] ). \* WATER COOLED ONLY

Weights	lbs.	kgs.
Net	176	79.8
Crated	207	93.9
Volume	cu. ft.	cu. m.
Volume	17.7	0.50

Dimensions	in.	mm.
Width	16-1/8	408
Depth	27-5/8	701
Height	27-9/16	700
Counter Clearance	--	--

Designed to rest on a plastic pad directly on counter top.

Electrical	Total Amps	Supplied with NEMA Cord
115/60/1 Air	16.0	5-20P
208-230/60/1 Air	9.5	6-15P
220-240/50/1 Air	7.6	----
220-240/50/1 Water	7.6	----

This unit may be manufactured in other electrical characteristics. Refer to the local Taylor Distributor for availability.

(For exact electrical information, always refer to the data label of the unit.)

### Bidding Specs

Electrical: Volt \_\_\_\_\_ Hz \_\_\_\_\_ ph \_\_\_\_\_  
 Neutral: Yes No **Cooling:** Air Water NA

Options: \_\_\_\_\_

## Specifications

### Electrical

One dedicated electrical connection is required. See the Electrical chart for the proper electrical requirements. Manufactured to be cord connected. Consult the international Taylor distributor for cord & receptacle specifications for 50 Hz. equipment.

### Refrigeration System

One, approximately 4,000 BTU/hr compressor. R404A. (BTUs may vary depending on compressor used.)

### Beater Motor

One, 1/4 HP.

### Air Cooled

Minimum Clearance: 3" (76 mm) on both sides. It is recommended to place the rear of the unit against the wall. Minimum air clearances must be met to assure adequate air flow for optimum performance.

### Water Cooled

Water inlet and drain connections out of rear 3/8" FPT.

## Options

- Flavor Burst Connection
- Graphic Panel Decals
- Panel Spinner
- Set of Four Flavor Cards; Frozen Drinks, Frozen Fruit Drinks, Frozen Cocktails, Smoothies

Continuing research results in steady improvements; therefore, these specifications are subject to change without notice.



Taylor Company,  
 Rockton, Illinois 61072  
 815-624-8333 800-255-0626 Fax 815-624-8000  
 www.taylor-company.com