

Trittico[®] Executive 610

Combined machine with ionic-system and double inverter
for pastry products, chocolate, savoury food and gelato
water cooled



Absolute Creative Freedom

Trittico[®] Executive is the first and only complete laboratory enclosed in just one machine: more than 40 years of innovation in less than 10 square feet. Trittico[®] Executive harbors the unique synergy of ancient experience, craftsmanship, and avantgarde technology in its very heart. For the art of pastry making, chocolate, top quality gelato, and for the highest levels of international cuisine.

Technical features

- Ingredients can be added during each heating or freezing phase
- Double inverter for upper tank stirrer with 3 speeds and batch-freezer mixer with 8 speeds
- Sheet resistance heating system: very quick heating process, no thermal hysteresis, high temperature precision, product never burns
- Patented ionic[®] System control: it detects the right percentage of frozen water in the mixture in order to obtain the proper gelato/sorbet consistency and volume
- Thermal shock due to fast temperature decrease from 85°C to 4°C: it allows the highest sanitizing of the product and the highest hygiene of the mixture
- Software programmed with multiple recipes
- Special whisk to whip
- Chute for direct extraction

Advantages and strengths

- Very easy and convenient product loading
- Mixing speed can be changed either automatically or manually
- Fast washing operations
- Max hygiene
- Extremely easy to handle and clean



Trittico Executive 610

Combined machine with ionic-system and double inverter for pastry products, chocolate, savoury food and gelato
water cooled

Model:
Quantity:
Project:
Company:
Contact:
Dealer ID:

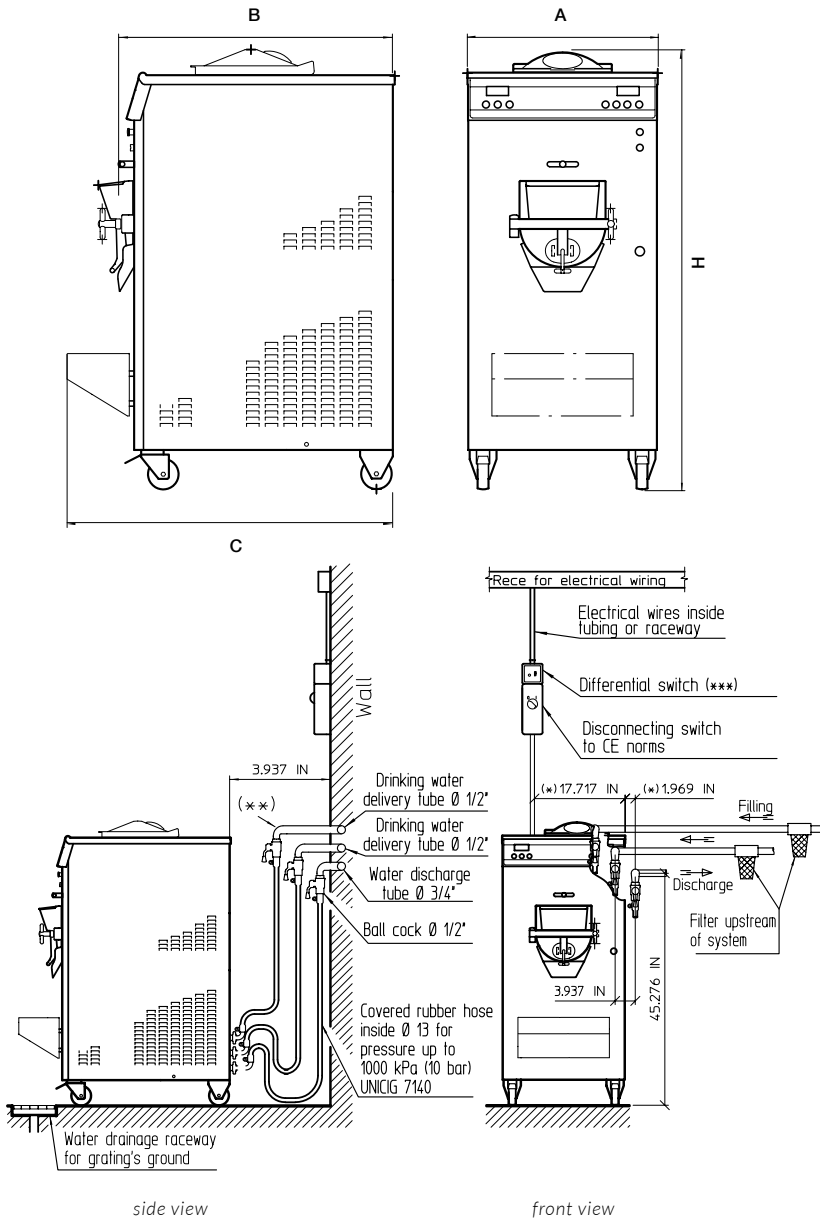

(*) Even if the machine models vary, the water and electricity connection positions are always the same, i.e. on the LEFT side of the machine.
(**) Cocks are in vertical only for illustration purposes.
(***) 30 mA (ABB serie C).



Warranty: valid for the North American Continent (Canada, USA)
Extension: 12 months parts (with check list and warranty signed and mailed)
5 years compressor with registration on warranty.bravonorthamerica.com

Width (A)	cm	61	inches	24
Depth (B)	cm	95	inches	37,4
Depth with base (C)	cm	102,5	inches	40,4
Height (H)	cm	141	inches	55,5
Weight	kg	346	lbs	763
Frame type	floor model			
Outer panels	stainless steel			
Capacity per cycle	Liters	10	Gal	2,64
Max. hourly production for gelato	Liters	60	Gal	15,85
Max. hourly production for pastry	based on the product that has to be produced			
Min. mix per cycle	Kg	4	Lbs	8,8
Max. mix per cycle	Kg	8	Lbs	17,6
Volume cylinder with mixer	Liters	15,83	Quarts	16,73
Volume cylinder without mixer	Liters	16,64	Quarts	17,58
Stirrer speed	3 speeds from 30 to 80 RPM			
Mixer speed	8 speeds from 20 to 300 RPM			
Max power	kw	9	Hp	11,9
Voltage	230 Volt / 60 Hz / 3 phase			
Running Amps	Amp 30,1			
Breaker size	Amp 60			
Stirrer motor	kw	0,22	Hp	0,3
Drive motor	kw	4-2,6	Hp	5,4-3,5
Compressor power	kw	2,8	Hp	3,75
Compressor power	BTU/h 9349			
Freon R404A	Gr	2000	Oz	70,5
Refrigeration condensation	Water			
Water connection	cm	1,27	inches	1/2
Min. water pressure	bar	1,5	psi	20
Max. water pressure	bar	3	psi	40
Crate dimensions	cm	110x80x172	inches	42,9x29x67,7
Crate weight	kg	437	lbs	965



Bravo North America Inc. Office & Showroom, 810 Tyvola Road, Suite 130, Charlotte, NC 28217
tel. +1 980 237 2474 bravonorthamerica.com info@bravonorthamerica.com